



Bulletin HY30-3245-INST/UK

# Installation and start-up information PV series

Design series  $\geq 44$ , *PVplus*

Effective: July 1, 2010

---

## Variable displacement axial piston pump



<b>Contents</b>	<b>Page</b>
1. Installation and start-up .....	3
2. Displacement adjustment.....	6
3. Standard pressure compensator, code ...MMC .....	6
4. Standard pressure compensator with D03 interface, code ...MM1 .....	7
5. Standard pressure compensator for accessory mounting, code ...MMZ.....	7
6. Remote pressure compensator, codes ...MRC, ...MR1 and ...MRZ .....	8
7. Load sensing compensator, codes ...MFC, ...MF1 and ...MFZ.....	8
8. Two spool load sensing compensator, codes ...MTP and ...MTK .....	9
9. Horse power compensator, codes ...*L*, ...*C* .....	10
10. Compensator accessories .....	11
10.1 Pressure relief pilot valve, code PVAC1P.....	11
10.2 Multiple pressure pilots PVAC1E..., PVAC2P..., PVAC2E... und PVAC2M.....	11
11. Trouble shooting guide.....	12

**Note: The compensator ordering code is represented by the last three digits of the pump ordering code (digit 13 to 15).**

**Note**

This document and other information from Parker Hannifin GmbH & Co KG, its subsidiaries, sales offices and authorized distributors provide product or system options for further investigation by users having technical expertise. Before you select or use any product or system it is important that you analyse all aspects of your application and review the information concerning the product or system in the current product catalogue. Due to the variety of operating conditions and applications for these products or systems, the user, through his own analysis and testing, is solely responsible for making the final selection of the products and systems and assuring that all performance and safety requirements of the application are met. The products are subject to change by Parker Hannifin GmbH at any time without notice.

## 1. Installation and start-up

For a safe and disruption free operation of any machine or system a careful installation and start up according to the manufacturers instructions is mandatory.

Hydraulic systems can be designed for many totally different functions and they require consequently different start up procedures. The hydraulic pump is in this respect only one, but nevertheless a very important component of the whole system.

A general start up instruction therefore can give many helpful hints but it needs to be completed by specific additions depending of the individual nature of the system or power unit.

During installation and start up the following steps need to be carried out carefully:

### Visual inspection

Make sure that all components of the shipment are complete, free of any damage, free of outside contamination and properly protected against ingress of contamination.

### Cleanliness

Contamination of any kind is the enemy of any hydraulic component. It is still the number one cause for component failure. Therefore **maximum care** and **cleanliness** are required during all handling and managing of parts that come in contact with the hydraulic fluid. All ports of the pumps and other components must be covered until pipes or hoses are mounted to them. Perform assembly preferably in a dry and dust free room. Use only suitable tools.

### Installation

Installation horizontal or vertical, avoid rigid connection from pump to reservoir cover or frame and to inlet and outlet piping to prevent excitation of the whole system due to pump vibrations.

### Suction port

Position to the side or to the bottom, max. fluid velocity approx.  $v = 1.0$  m/sec, cut suction pipe inlet under  $45^\circ$ . Minimum distance from bottom 2 - 3 times diameter and, even at lowest fluid level, approx. 200 mm below fluid level. Inlet pressure, even during compensation, never should drop below 0.8 bar (absolute).

Absolute gas tight connection (risk of cavitation, noise). Air bubbles due to vacuum in the inlet can destroy pumps within a short time due to cavitation erosion. Suction pipe should be as short as possible. Use only clean, low pressure pipe, avoid sharp elbows and any restriction of cross section.

The suction pipe must have access to clean, cooled and filtered fluid, free of air bubbles. No turbulences or high flow velocities should occur at the tube inlet. Therefore position inlet as far as possible away from return line and drain line. Make sure that the fluid circulation in the reservoir does keep return flow from suction pipe inlet. In case of positive head use shut off valve in the inlet, monitored with proximity switch or equivalent to avoid start up of motor when valve is closed. When installed into the reservoir use short suction pipe with pipe end cut under  $45^\circ$ .

### Pressure port

Select correct pressure rating for pipe, hose and connectors. Take pressure peaks into account. Dimension the piping according to the port size. Prevent excitation of the system by using flexible port connections.

### Drain port

Always use highest possible drain port of the pump. Drain port must be higher than pump centerline or install additional air bleed line. Never combine pump drain line with other return lines and/or drain lines. Pump shall not be able to run empty. Max. allowable case pressure  $\leq 0.5$  bar (2 bar peak), also during compensation.

Use low pressure pipe/hose, as short as possible and full cross section according to port dimension. Do not use elbows or sharp corners. When drain port is on the side of the pump drain line should have bridge higher than pump top (also when installed in reservoir). Drain pipe must end at least 200 mm below fluid level even at lowest filling level. Never let drain flow go direct into suction area of reservoir (temperature, air bubbles). Max. length 2 m, otherwise use larger pipe diameter than port size.

Note: During operation of PV pumps of all sizes under the following conditions:

$$Q \sim Q_{\max}$$

$$p_{\text{inlet}} < 2 \text{ bar absolute}$$

$$P_{\text{outlet}} < 25 \text{ bar}$$

(e. g. low pressure circulation) the drain flow can change direction. Fluid is taken from the case into the piston mainly through the decompression orifice and across the slippers. There is a danger that the pump case runs dry, the pump overheats and the bearings lack of lubrication when the fluid is removed from the pump case.

Therefore the drain pipe must be able to take fluid from the reservoir. That means: The drain line must end below fluid level, and a check valve in the drain

**Port positions for PV (shown for clockwise rotation, for ccw rotation ports are mirrored)**

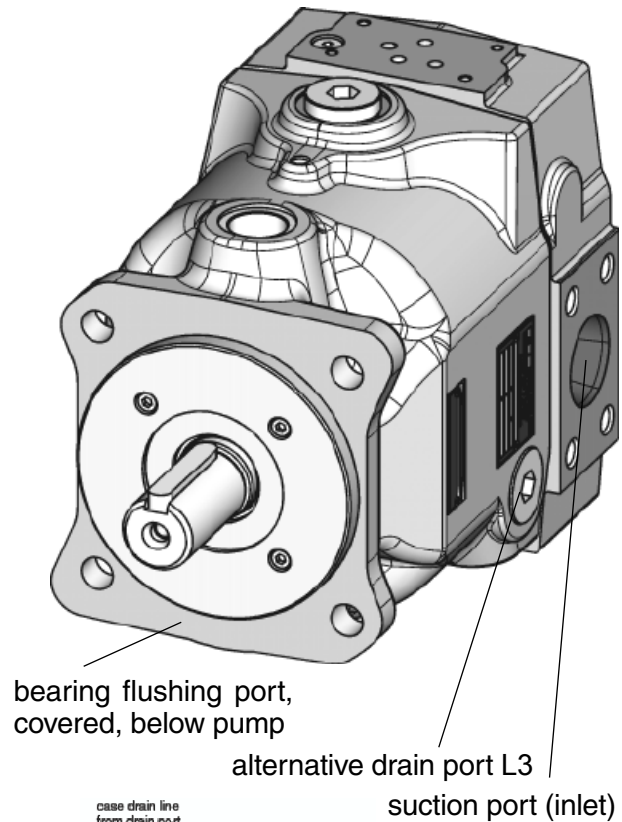
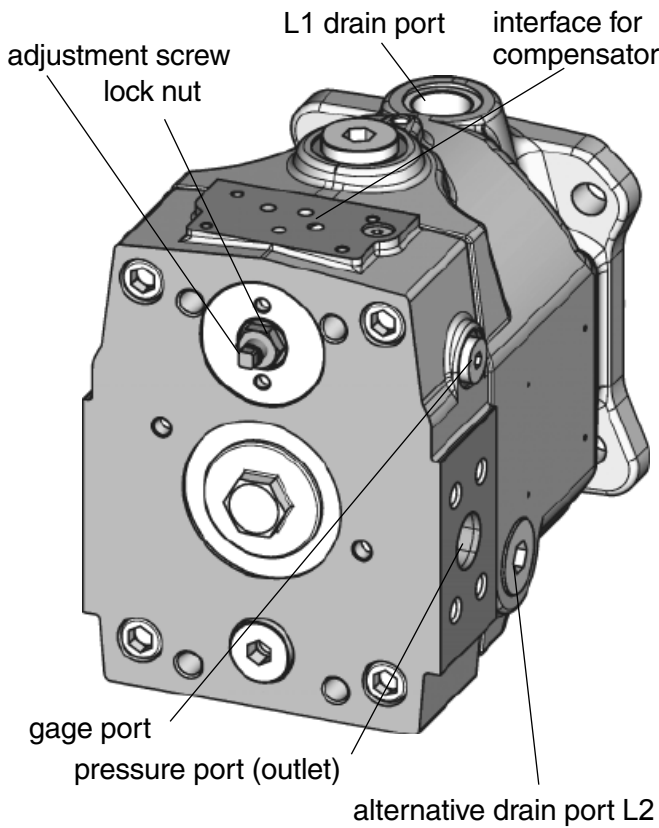

line is not permissible. If it has to be installed for whatever reason the case needs to be flushed with a flow of 10 - 15% of the nominal pump flow.

For side mounting (suction port facing down) use alternative drain port 1 (cw rotation) or 2 (ccw rotation).

**Flushing port**

The PV pumps of design series 44+ are equipped with three drain ports\*. In addition pumps with seal option W and P, all pumps PV140 - PV360 and pumps with X-modification X5830 (bearing flushing port) are equipped with a flushing port for front bearing and shaft seal. The flushing flow can - depending on the actual working conditions - be used to keep the pump case filled, to warm up the pump (during cold temperature operation) or for better heat dissipation e. g. for operation with HFC fluids (water glycole) to keep the case fluid temperature in the allowed range. Permanent dead head operation (>15 min) either for pumps of frame size 3 and larger (PV063 and higher) or at high input speeds above 1,800 rpm requires flushing of the pump case.

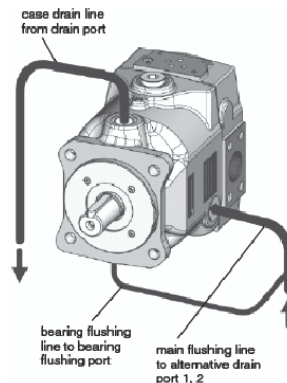

\* PV016-092+PV270-PV360 DS45  
 Port L1 on top ; L2,L3 at the side  
 L4 at bottom (standard: PV270-360)

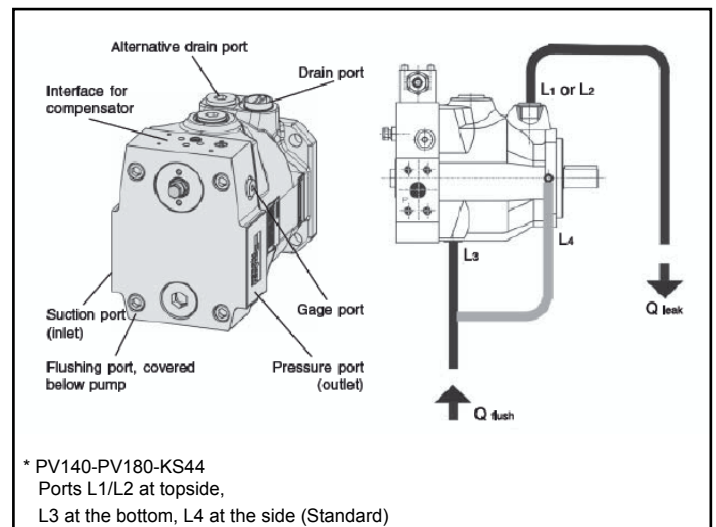

\* PV140-PV180-KS44  
 Ports L1/L2 at topside,  
 L3 at the bottom, L4 at the side (Standard)

Flushing should be taken from the filter/cooling circuit (e. g. pre-loaded return line). Recommended flushing flows see following table.

PV016 - PV028	4 - 6 l/min
PV032 - PV046, PV076	5 - 8 l/min
PV063 - PV092	7 - 10 l/min
PV140 - PV180	9 - 12 l/min
PV270 - PV360	13 - 17 l/min

(flushing flow for front bearing: 10 - 15% of the total flushing flow)

### Drive input

For direct drive use elastic coupling free of axial and radial reaction forces. Please follow strictly the instructions of the coupling supplier regarding axial clearance, axial displacement and angular tolerances. Couplings never shall be mounted using a hammer. Threads in the shaft end allow smooth mounting of the coupling.

The drive shaft should only carry true torque. Contact Parker for allowable side loads or axial forces.

PV pumps are normally for one direction of rotation only. Therefore check rotation of drive motor prior to installation.

### Electrical interface

Check voltage, current, phase and connection properties. Verify direction of motor rotation.

### Fluid reservoir

The reservoir needs to meet all system requirements concerning design, size, location and porting. Beside being reservoir for the hydraulic fluid, the tank also supports heat dissipation, air removal, water removal and contamination sedimentation. Often the reservoir also is the fundament for the motor pump unit. In this case the separation of pump and remaining structure by elastic means is mandatory to avoid noise and vibration being induced into the frame work. The reservoir needs to be carefully sealed against ingestion of contamination and water. A level indicator and thermometer should be placed in an easily accessible location.

Fluid content (general rule): stationary systems 3 to 4 times pump nominal flow, 1 times or even smaller in mobile systems.

### Filling of the system

Use only high quality mineral oil based fluids, like HLP oils according to DIN 51524 part 2. For other fluids (HFC, HFD, bio degradable or synthetic fluids) please contact Parker and review the Hydraulic Fluids Information in Catalogue 2500/UK.

Operation viscosity should be 16 to 100 mm<sup>2</sup>/s, optimum viscosity range is in the 20 to 40 mm<sup>2</sup>/s, max. viscosity for short time up to 320 mm<sup>2</sup>/s.

Because of the possibly incompatible ingredients fluids should not be mixed (separation of fluid, reduction or loss of fluid properties).

### Pay highest attention on cleanliness!

Fill system only via a filtration device. Use filtration unit, when basic contamination of the refill fluid exceeds class 10 according NAS 1638 (contamination level 21/19/16 according to ISO 4406). Hydraulic fluid supplied in barrels typically exceeds these contamination levels.

### Filtration

Filtration is the most important factor to the operational life of the hydraulic system. Statistical analyses indicate, that contamination is by far the most important reason for system or component failure.

Use return line, pressure and/or bypass filtration. Bypass filtration usually is most efficient. For general purpose hydraulic systems with limited requirements for operational life contamination level 19/15 according to ISO 4406 should be desired; corresponding filter rating:  $x = 25 \mu\text{m}$  ( $b_{25} \geq 75$ ) according to ISO 4572.

Cleanliness level for systems with higher requirements for operational life and functional safety should be 18/16/13 according to ISO 4406; corresponding filter rating  $x = 10 \mu\text{m}$  ( $b_{10} \geq 75$ ) according to ISO 4572.

Use filter with indicator or electrical signal when capacity limit is approached.

Suction filter should be avoided. Suction conditions will be affected. Filter can be blocked and cause cavitation and severe pump damage. When used, a vacuum sensor with shut off function is mandatory.

Properly dimensioned breather rating  $\leq 10 \mu\text{m}$  should be used. Observe min. and max. fluid level; consider exchange volume with cylinders in the system.

### Filling of pump case

Pump case must be filled via the drain port, to ensure lubrication, sealing and smooth start up.

**Start up**

Check if all ports are properly connected according to the specification, all connectors are tightened and all adjustments are made.

Open suction valve (if installed)!

Switch system to free circulation or to lowest pressure. Allow air bleeding for quick priming. Start pump in tip mode operation until pump and all pipes are filled and free from air bubbles. If pump does not build up pressure, double check the installation.

Raise pressure setting only when all air is removed. Let the pump work at reduced pressure for 5 - 10 min, check if all pipes and connections are leak free and tight.

Observe reservoir: fluid level, built up of foam, fluid temperature. When system is warmed up first functional tests can be performed.

**2. Displacement adjustment**

All axial piston pumps of the PV series are equipped with an adjustable displacement limiter.

The servo piston stroke is limited at full displacement by a screw, guided in the end cover plug of the servo piston bore. The screw is protected against unintentional adjustment by a self-sealing lock nut (see figure on page 4).

The factory setting of the displacement is according to the nominal displacement of the pump. An adjustment may only be made to a lower displacement (turning screw in). An adjustment to a higher than the nominal displacement can destroy the pump.

Adjustment should only be made with the pump working at full displacement (not compensated) and at a low output. At full displacement the piston area of the servo piston is under case pressure. Opening the self-sealing nut will only cause a negligible leakage under these conditions.

Turning the adjustment screw clockwise will reduce the pumps displacement. For the sizes PV016 – PV092 the thread pitch is 1mm, for sizes PV140 – PV360 the thread pitch is 1.5 mm. The table shows the displacement change per mm resp. per turn and the minimum adjustable displacement.

**Note:** All pumps are adjusted and tested after assembly in our factory. Only the compensator pressure needs to be adjusted. That is done on the pilot valve spindle. No other adjustments on the compensator or the pump is required. Only after service or repair a basic adjustment needs to be performed.

Baugröße / Size	Änderung Förderstrom per mm / Displacement change per mm (ca. cm <sup>3</sup> /U)	Änderung Förderstrom per Umdrehung / Displacement change per turn (ca. cm <sup>3</sup> /U)	min. einstellbares Fördervolumen / min. adjustable displacement ca. cm <sup>3</sup> /U
PV016	1,5	1,5	9
PV020	1,5	1,5	13
PV023	1,5	1,5	16
PV028	1,5	1,5	20
PV032	2,2	2,2	17
PV040	2,2	2,2	25
PV048	2,2	2,2	30
PV078	2,2	2,2	40
PV083	3,4	5,1	35
PV080	3,4	5,1	50
PV092	3,4	5,1	65
PV140	5,6	8,4	20
PV180	5,6	8,4	60
PV270	6,8	10,2	120
PV360	8,6	12,9	180

**3. Standard pressure compensator, code ...MMC**

The adjustment of the compensating pressure is performed for the standard pressure compensator directly at the compensator.

To adjust the pressure, the lock nut (SW 13) is to be loosened and the adjustment spindle is to be turned (screw driver).

Turning clockwise will increase the compensating pressure, turning counter-clockwise will decrease the compensating pressure.

The compensating pressure can be adjusted in a range from 15 to 350 bar (approx. 100 bar/turn).

By turning the pressure pilot cartridge housing the compensator differential can be adjusted. It is factory set to 15±1 bar and should not be changed (approx. 20 bar/turn).

Different compensator differential settings can cause instability or excessive power losses.

By using adapter kit PVCMMCK\*\* the standard pressure compensator can be made remote controllable. This adapter replaces one of the side plugs. Adapters are available for G1/4, M12x1.5 ISO 6149 and 7/16-20 UNF.

See also the remarks in chapter 6.

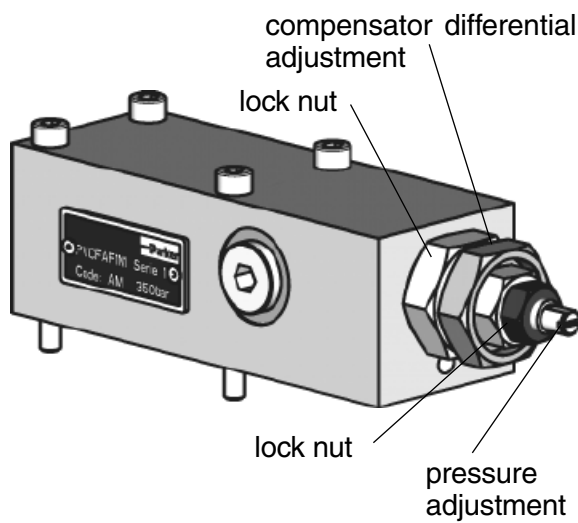

**4. Standard pressure compensator with D03 interface, code ...MM1**

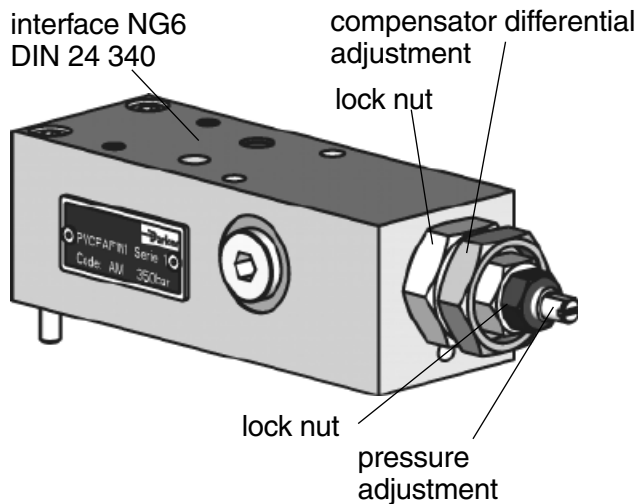

The standard pressure compensator code ...MM1 has topside an NG6/Cetop 3/NFPA D03 interface for the mounting of suitable pilot valves. This compensator can for example be directly equipped with a proportional pressure pilot valve for electrical pressure setting (ordering code ...MMK, see figure on page 9).

The pilot valve must be capable of pilot flows of approx. 1,2 l/min. Therefore a nominal flow range of 3 - 6 l/min is recommended. A too small as well as a too large pilot valve can lead to unsatisfactory compensator performance.

In addition the compensator can be equipped with a directional control valve for stand-by (unloading) functions (ordering code ...MMW, see figure on page 9).

**Please note:** when mounting accessories (e. g.: proportional pressure pilot valve) or external (remote) control the integrated pilot valve first must be turned in to avoid too early pressure limitation.

**5. Standard pressure compensator for accessory mounting, code ...MMZ**

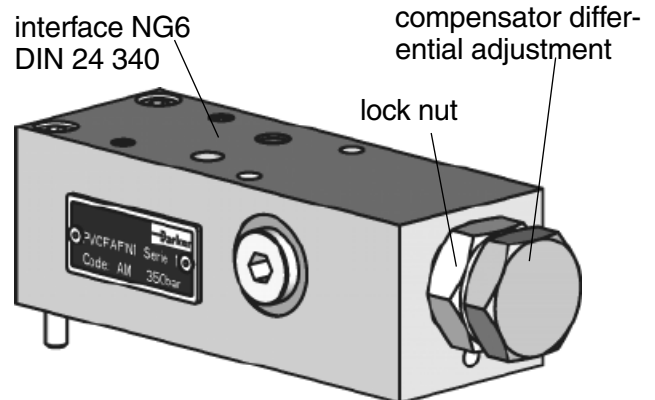

Version ...MMZ is designed especially for compensator accessory mounting (ordering code PVAC..., see chapter 12).

Because the accessory packages come with their own pilot valves, this version has no integrated pilot cartridge to avoid unwanted interaction.

For more details on the different compensator options see also the PV compensator spare parts manual for compensator design 45, Parker bulletin PVI-PVC-45-GB.pdf.

**Note:**

Checking and adjusting the compensator differential should always be done by using two pressure sensors/gages. Measuring one pressure only (pump outlet pressure) and assuming, that the pilot pressure at fully unloaded pilot valve resp. with unload proportional pilot valve is 0 bar can lead to completely wrong adjustments.

The different pilot valves can cause even at the nominal pilot flow (1,2 - 1,4 l/min) already significant back pressures which add to the compensator differential.

Only if the pilot pressure chamber is completely unloaded (e. g.: when one of the side plugs is removed or the DCV is in stand-by mode) it can be assumed, that the pilot pressure is zero and pump outlet pressure is equal to the compensator differential setting.

**6. Remote pressure compensator, codes ...MRC, ...MR1 and ...MRZ**

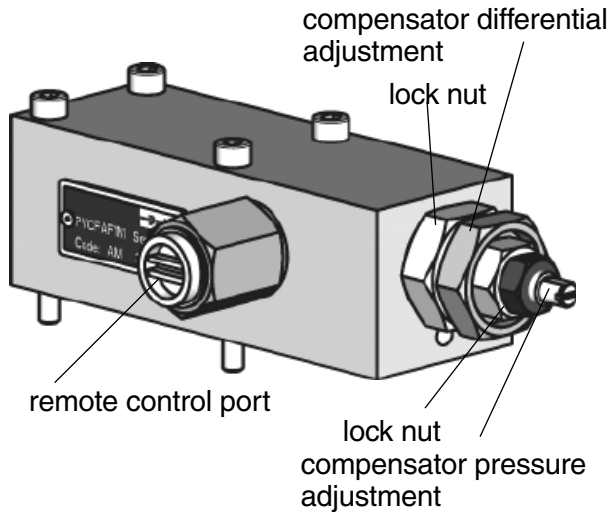

The remote pressure compensators code ...MR\* are equipped with a remote control port. To this port external pilot valves can be connected. The distance between pump and pilot valve can be up to 15 m. The pilot line should be designed, to avoid pressure losses.

Especially at low environmental temperatures a too narrow pilot line can result in a significant pressure increase. The nominal pilot flow is in the range of 1.2 to 1.4 l/min.

Beside the version shown above (code ...MRC) also a version ...MR1 with a topside NG6 / D03 interface is available as well as a version ...MRZ without integrated pilot valve for the use with compensator accessories code PVAC... .

For the compensators with code ...MM\* and ...MR\* the pilot pressure supply is maintained through an orifice located in the control spool.

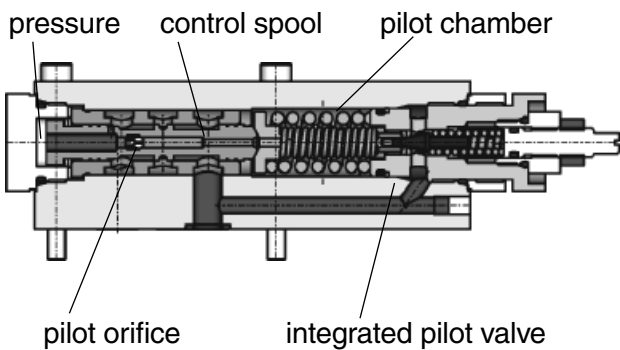

**7. Load sensing compensator, codes ...MFC, ...MF1 and ...MFZ**

The load sensing or flow compensator primarily controls the pump output flow. To achieve this the load pressure after a main stream throttle valve (load sensing valve, not included in the shipment of the pump) is connected to the load sensing port of the compensator. The compensator control strategy is, to keep the pressure drop constant across this main stream throttle valve.

The integrated pilot valve maintains a pressure compensation when the adjusted max. pressure is reached. The pilot orifice  $\varnothing 0,8$  mm is located in the load sensing port adapter. This orifice replaces the orifice in the control spool of the ...MM\* and ...MR\* compensators, because pilot pressure is in the load sensing compensator provided through the load sensing line.

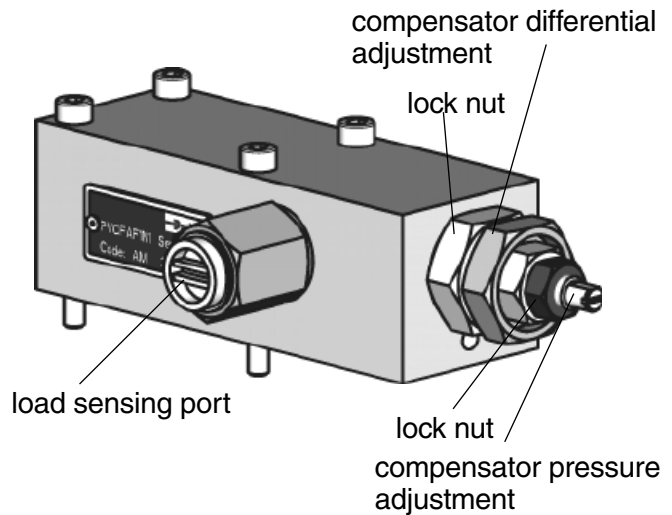

Load sensing and pressure compensators only differentiate by the control spool and by the location of the pilot orifice.

Beside the version shown above (code ...MFC) also a version ...MF1 with a topside NG6 / D03 interface is available as well as a version ...MFZ without integrated pilot valve for the use with compensator accessories code PVAC... .

The following port options are available for remote pressure and load sensing compensators:

thread and port code	port thread dimensions
1	G 1/4 BSPP
3	7/16-20 UNF
7, 8	M12 x 1,5 ISO 6149-1

The length of the load sensing line can be up to 15 m. If the line is longer than 5 m it has to be considered, that low environmental temperatures and high fluid viscosity can have a negative influence to the compensator performance.

The line should be designed to avoid any significant pressure drop.

Factory setting for the load sensing pressure differential is 10 bar ± 1 bar. This adjustment should only be changed in exceptional cases.

The adjustment is possible by turning the pilot valve housing after loosening the lock nut.

Please refer to the setting instructions on page 7.

All compensators described in chapters 3 - 6 can be shipped with a directional control valve for stand-by operation (compensator codes ends with..W) or with a proportional pilot valve for electrical pressure adjustment (compensator code ends with ..K)

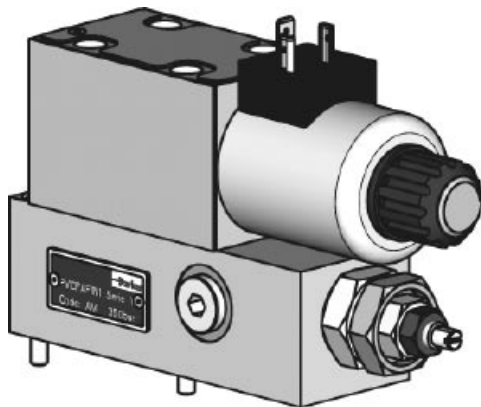

Compensator code ...MMW with directional control valve code D1VW2K\*JW for stand-by operation (24 VDC, normally open)

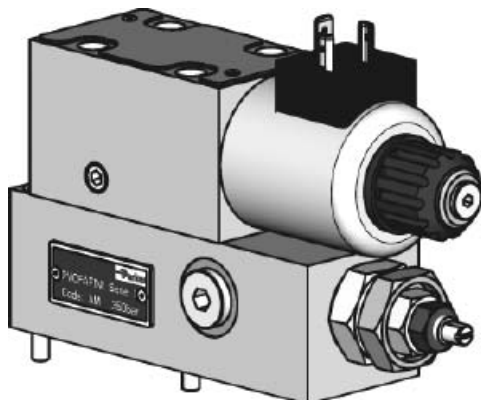

Compensator code ...MMK with proportional pressure pilto valve code PVACRES-\*35

**8. Two spool load sensing compensator, codes ...MTP and ...MTK**

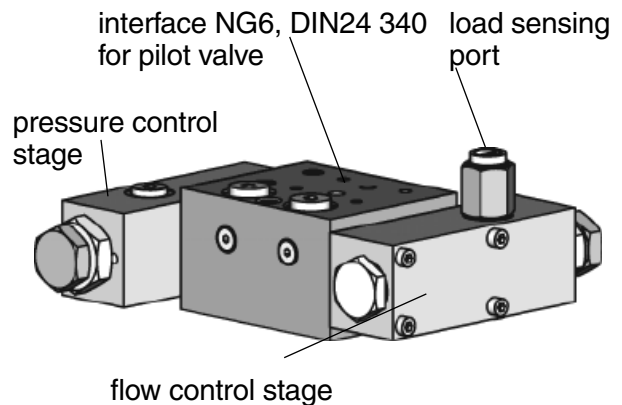

The two spool compensator, code ...MT\* has two separate compensator valves for flow (load sensing) and pressure compensation.

That results in a steeper pressure compensation curve, which can be beneficial in certain applications.

The flow control stage has no integrated pilot valve, because this would eliminate the effect of the two spool control. The pressure stage has no integrated pilot valve, because during flow control the T port of the pressure compensator is under control pressure. This would prevent the pilot valve from opening.

With the adapter kit PVCMMCK.. the pressure compensator can be made remote controlled.

On the topside interface any pressure pilot valve can be mounted. See chapter 3 for requirements.

The factory setting of the flow compensator is 10 ± 1 bar, the adjustment for the pressure compensator is 15 ± 1 bar. These adjustments should not be modified.

If different adjustments are required by the system or by the load sensing valves used in the system, see page 7 for setting instructions.

With ordering code ...MTP a manual adjustable pressure pilot valve code PVAC1PM\*S35 is mounted on the elbow manifold.

With ordering code ...MTK a proportional pilot valve code PVACRES-\*35 is mounted on top. For electronic pressure control a suitable power amplifier is required. We recommend the digital modules PCD00... supplied by Parker HCD.

Because the two spool compensator has no integrated pilot valves, for a stand-by function the compensator accessory PVAC1EM\*C\*\*35, including a directional control valve and a pilot section, is required.

**9. Horse power compensator, codes ...\*L\*, ...\*C\***

Depending on its type, the horse power compensator consists of a remote pressure compensator or a load sensing compensator in combination with the horse power pilot cartridge. The opening pressure of this pilot cartridge depends on the actual displacement of the pump. At large displacements the opening pressure is low. As the displacement is reduced the opening pressure is increased according to the form of the contour sleeve in the pump. That leads to the desired control characteristic (constant input horse power).

That is achieved by having the pilot cartridge seat being guided by the contour sleeve. This contour sleeve is firmly connected to the servo piston. The contour represents the desired input horse power.

The horse power pilot cartridge is internally connected to the compensator valve. Compensator valves for horse power compensated pumps differ from standard compensator valves only in the fact, that a plug in a connecting hole is removed.

For a standard horse power compensator with ordering code ...\*L\* a modified remote pressure compensator is used. For a horse power compensator with load sensing, code ...\*C\* a modified load sensing compensator is used.

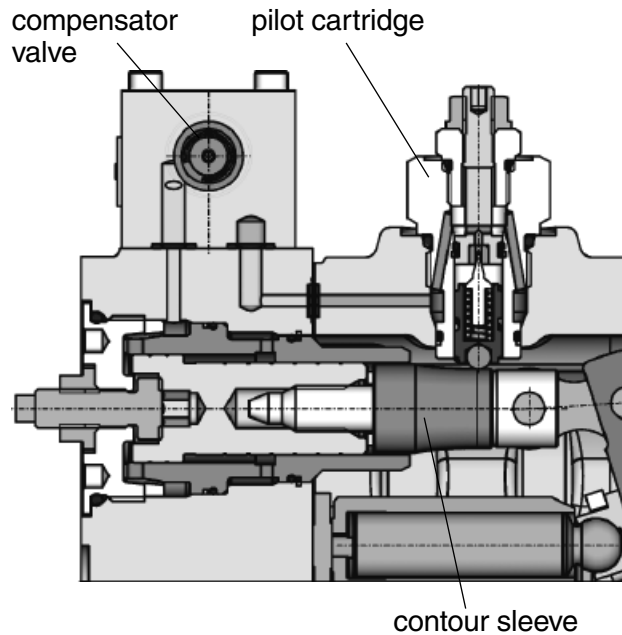

Partial section through a horse power controlled pump

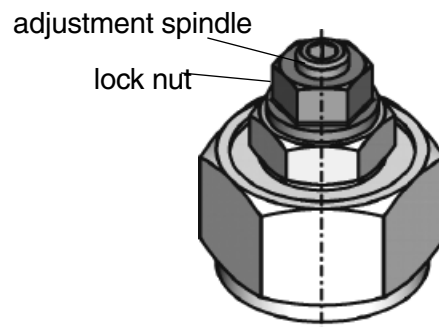

**Horse power pilot cartridge**

At the adjustment screw of the horse power pilot valve a basic adjustment of the horse power compensator can be made. After loosening the lock nut (self sealing nut) the compensator control curve can be moved by turning the adjustment screw (adjustment A in the diagram left). This adjustment, done to meet the required constant input horse power curve, is already made during the factory test and should be modified only in exceptional cases.

To adjust the correct constant horse power curve a measuring device is required. An output power measurement requires pressure and flow metering. An input power measurement requires torque and speed measurement or a measurement of the electric motor current.

Note: For horse power control the load sensing differential is set to  $15 \pm 1$  bar. Any change will result in a deviation from the horse power setting.

**Note:** The setting is very sensitive, 0,1mm change of the spindle changes the pressure approximately 20 bar.

**Constant horse power curve with adjustment**

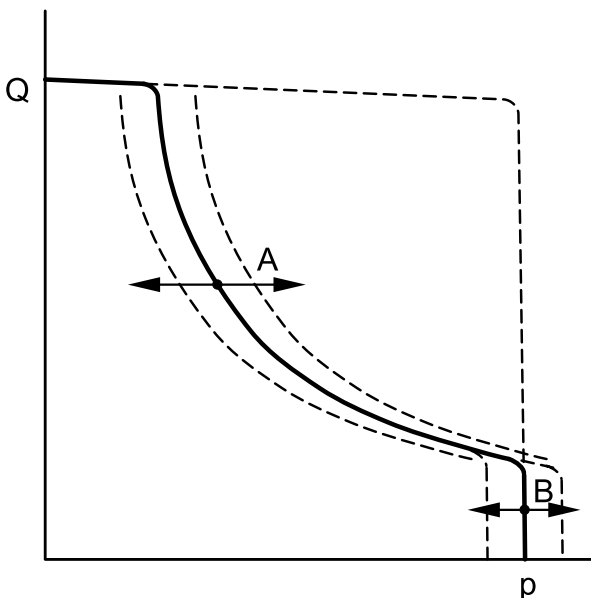

Adjustment A: tolerance compensation for optimized performance; done at pilot cartridge.

Adjustment B: maximum pressure setting; done at integrated pressure pilot valve.

**10. Compensator accessories**

**10.1 Pressure relief pilot valve, code PVAC1P...**

The pressure relief pilot valve code PVAC1P... is optimally tuned for the requirements of the compensator valves of the series PV. It has a mounting interface NG6 according to DIN 24340 and can be mounted directly on top of all compensator valves with the topside mounting interface.

Such a valve is only necessary for the compensators with elbow manifold (...MT1 and ...UPR) and for the versions without integrated pressure pilot cartridge (compensator code ends with..Z). All other versions include an integrated pilot valve.

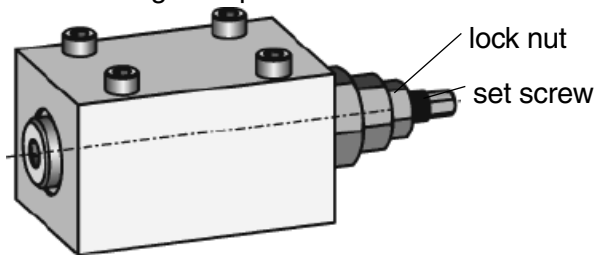

After loosening the lock nut SW13 an adjustment of the compensating pressure for the pump is possible in a range of approx. 20 bar up to 350 bar.

The pressure pilot valve is also available with a DIN lock.

**10.2 Multiple pressure pilots PVAC1E..., PVAC2P..., PVAC2E... und PVAC2M...**

For multiple pressure pilots, codes PVAC2P..., PVAC2E... and PVAC2M... a sandwich valve with two direct-action pressure cartridge valves is used to pilot the pump.

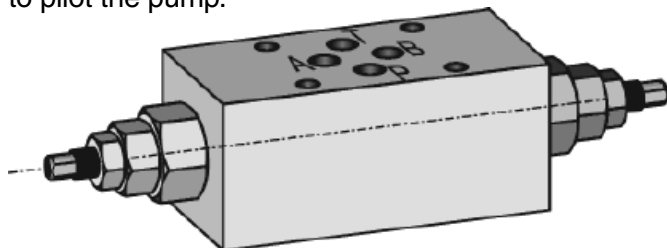

For code **PVAC2P...** a single solenoid directional control valve is included for pressure selection. The valve switches between low pressure setting and high pressure setting. During low pressure both pilot cartridges are connected to the compensator, in the high pressure setting (solenoid energized) only the A-side cartridge is connected. Therefore the B-side pilot needs to be set for lower pressure. The directional control valve series D1VW has spool code 6.

For code **PVAC2E...** for pressure selection a two-solenoid DCV is included, which selects between low pressure setting, high pressure setting and stand-by pressure. In neutral position both cartridges are con-

nected to the compensator valve. The lower pressure defines the compensating pressure of the pump. When the A solenoid (B-side) of the DCV is energized only the A-side cartridge is connected; the (higher) pressure adjusted there defines the compensating pressure.

When solenoid B is energized the valve spool connects all four ports. Then the spring chamber of the compensator valve is directly relieved to the case drain of the pump, the pump compensates at minimum compensating pressure (stand-by).

The directional control valve series D1VW has spool code 55. This spool code is used to avoid a blocked spool position during transient.

This version is recommended, when during a machine cycle the pressure is to be switched between high and low.

For code **PVAC2M...** also a dual solenoid valve is used. In neutral position all four ports are connected. The compensator spring chamber is relieved to case drain, the pump is compensating at min. compensating pressure (stand-by).

When energizing solenoid A (B-side) the spring chamber is connected to the A-side pilot cartridge; the pressure adjusted here controls the pump.

When solenoid B is energized the spring chamber of the compensator is connected to pilot cartridge B; then the pressure adjusted on this cartridge defines the pump compensating pressure. The DCV of series D1VW has spool code 2.

This version should be used, when stand-by operation should be the default situation.

Code **PVAC1E...** is similar to code PVAC2P..., with the exception, that only one pilot cartridge is installed. In neutral position of the D1VW the stand-by pressure is selected.

Additional information can be found in: compensator spare parts manual PVI-PVC-UK-45 compensator accessories spare parts manual PVI-PVAC-UK

pumps spare parts manuals PVI-\*\*\*-UK-45 with \*\*\* = BG1 to BG5 according to pump frame size.

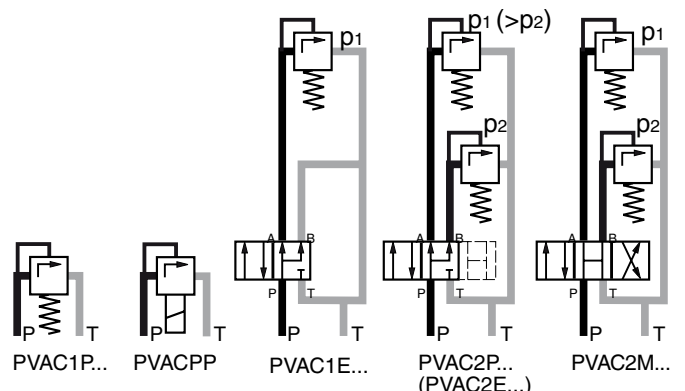

**11. Trouble shooting guide****Pump delivers no output flow.****Drive motor does not turn.**

Reason Motor is not connected correctly or one of the three phases has failed. Motor does not turn smoothly when pump is disconnected from pump.

Solution *Check motor connections, check electrical power supply.*

Reason Pump mechanically blocked. Motor turns smoothly when disconnected from pump.

Solution *Send pump to factory for service.*

**Drive motor only turns at slow speed.**

Reason Motor is not selected properly. In star circuit not enough torque.

Solution *Start pump at unloaded system. Use motor with more horse power.*

Reason Pump is hydraulically blocked. No function of compensator, no pressure relief valve. Pump stops after a few turns.

Solution *Check function of pump compensator (see below). Start pump at unloaded system.*

**Drive motor turns, pump does not turn.**

Reason Coupling is not or not correctly mounted.

Solution *Check coupling assembly and correct it.*

**Drive motor turns and pump turns.**

Reason Wrong direction of rotation.

Solution *Change direction of motor rotation.*

Reason Fluid reservoir empty or not filled to level, suction line ends above fluid level.

Solution *Fill reservoir to required level, if necessary increase suction pipe length.*

Reason Suction line is blocked. E. g. by plugs, cleaning tissues, plastic-plugs. Ball valve in the suction line closed. Suction filter blocked.

Solution *Check suction line for free flow. Open valves in suction line. Valves should be equipped with electrical indicator. Check suction filter.*

Reason Suction line not gas tight, pump gets air into suction port.

Solution *Seal suction line against air ingress.*

Reason Pressure line / system is not able to bleed air out.

Solution *Unload pressure port, unload system before start, bleed air from pressure line.*

**Pump does not build up pressure, but delivers full flow at low pressure.**

Reason Standard pressure compensator is set to minimum pressure.

Solution *Adjust compensator setting to desired pressure.*

Reason Orifice in remote pressure compensator blocked.

Solution *Make sure orifice  $\varnothing$  0.8 mm in control spool is free and open.*

Reason No pressure pilot valve connected to port P<sub>R</sub>.

Solution *Install suitable pressure pilot valve and adjust it to the desired setting.*

Reason Multiple pressure pilot selector valve is not energized. Pump works in stand-by.

Solution *Energize selector valve solenoid.*

Reason No load sensing line connected.

Solution *Connect system load sensing port to compensator.*

Reason Load sensing valve is closed or too small.

Solution *Open load sensing valve, use larger valve size.*

Reason Too much pressure drop between pump and load sensing valve.

Solution *Make sure connection is wide enough and has not too much pressure drop.*

Reason Differential pressure at compensator is adjusted improperly (too low).

Solution *Check differential pressure adjustment and correct it as described above.*

**Installation Manual**

Reason	Horse power compensator setting changed.
Solution	<i>Check setting of horse power compensator and correct it, if required.</i>
Reason	Proportional displacement control is not connected as required.
Solution	<i>Check wiring; connect according to installation manual for electronic module.</i>
Reason	Displacement transducer (LVDT) adjustment changed.
Solution	<i>Correct zero setting at displacement transducer.</i>
Reason	Electronic module has no supply power.
Solution	<i>Make sure module is powered with 22 - 36 V DC.</i>
Reason	Plug instead of orifice Ø 0.8 mm in the load sensing line to pump.
Solution	<i>Install orifice as required.</i>
Reason	Cylinder block lifts from valve plate due to excessive wear.
Solution	<i>Send pump to factory for service.</i>
<b>Pump does not compensate.</b>	
Reason	No orifice is in load sensing line to compensator code FFC.
Solution	<i>Install orifice Ø 0.8 mm as shown in circuit diagram (page 9).</i>
Reason	No pressure pilot valve connected to compensator or valve is blocked.
Solution	<i>Connect pressure pilot valve to compensator, make sure valve opens as required.</i>
Reason	Load sensing line connected incorrectly (e. g. upstream of load sensing valve)
Solution	<i>Connect load sensing line downstream (actuator side) of load sensing valve..</i>
Reason	No or too low pressure at pump outlet port.
Solution	<i>Pump outlet pressure must be at least 15 bar, because otherwise the bias spring in the pump cannot be compressed.</i>
<b>Pump does not upstroke, sticks at zero displacement.</b>	
Reason	Compensator is blocked due to contamination.
Solution	<i>Clean hydraulic fluid, clean compensator valve.</i>
Reason	Cable to LVDT or proportional solenoid is interrupted.
Solution	<i>Check wiring and make sure cable is ok. Replace if necessary.</i>
<b>Compensator is unstable.</b>	
Reason	Compensator spool sticks, due to contamination of hydraulic fluid.
Solution	<i>Clean hydraulic system, clean compensator valve.</i>
Reason	Compensator differential pressure changed (too low or too high).
Solution	<i>Adjust compensator differential pressure to required setting.</i>
Reason	Wrong pilot orifice or pressure pilot valve improperly selected.
Solution	<i>Select pilot orifice and pressure pilot valve as recommended.</i>
Reason	Dynamic critical system, e. g.: pressure compensator combined with pressure reducing valve, load sensing (flow) compensator combined with flow control valve.
Solution	<i>Use remote pressure compensator instead of standard pressure compensator, install orifice in load sensing line remote from compensator (as close as possible to load sensing valve).</i>

**For additional questions, your need of spare parts or in case of service needs please contact:**

**Parker Hannifin GmbH**  
Pump and Motor Division  
Neefestr. 96  
09116 Chemnitz  
Tel.: +49-(0)371 / 3937-0  
Fax: +49-(0)371 / 3937-488  
Internet: www.parker.com



**Parker Hannifin GmbH**  
Pump and Motor Division  
Neefestr. 96  
D 09116 Chemnitz  
Tel.: +49-(0)371-3937-0  
Fax: +49-(0)371-3937-488  
[www.parker.com](http://www.parker.com)

HY30-3245-INST/UK

Copyright © 2010  
by Parker Hannifin GmbH